











	X 4		X 8
	X 4		X 4
	X 4		X 4
	X 1		X 8
	X 4		

	X 4		X 4
	X 4		X 4
			X 2



	 	M1	M2
---	---	----	----

			M1	M2
FIAT	Multipla I	5p (98→03)	7,4	4,9
FIAT	Multipla II	5p (04→)	7,4	4,9
INFINITI	Q30	5p (16→)	11,1	7,7
MERCEDES	A (W176)	5p (13→15)	11,4	7,6
MERCEDES	B (W246)	5p (12→14)	12,9	10,4
MERCEDES	B (W246)	5p (15→)	12,9	10,4
MERCEDES	CLA (C117)	4p (13→15)	10,4	9,1
MERCEDES	CLA (C117)	4p (15→)	10,9	9,6
MERCEDES	CLA Shooting Brake (X117)	5p (15→)	10,9	7,4
MERCEDES	GLE Coupé (C292)	5p (15→)	6,9	9,9

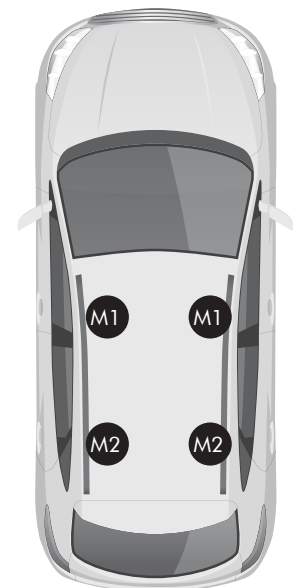

1a

4 x

Clik!

K1 MEDIUM  
 K1 PRO  
 K1 PRO ALU

1b

4 x

K1  
 K1 MEDIUM  
 K1 PRO  
 K1 PRO ALU

2

4 x

3

4 x

4

2 x M1

M1 M1b

→ M1

← M2

