













	X 4		X 8
	X 4		X 4
	X 4		X 4
	X 1		X 8
	X 1		

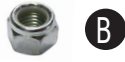





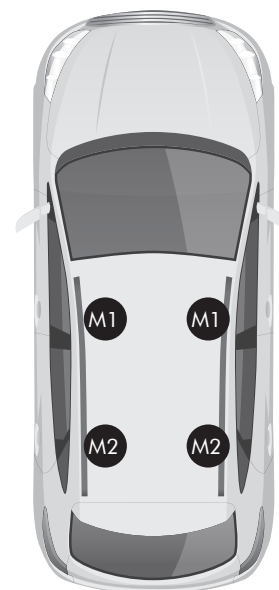
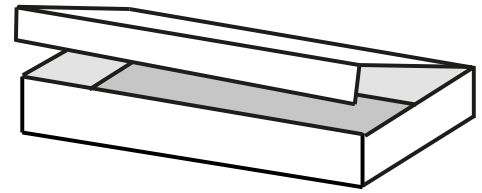
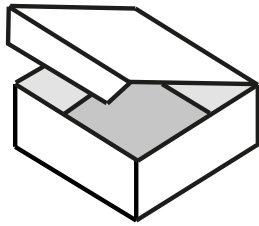

	X 1		X 4
	X 4		X 4
			X 2





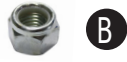

		M1	M2
BMW	SERIE 3 5P E46 (97→05)	8,4	8,0
BMW	SERIE 3 BERLINA E90 (05→11)	11,4	11,4
BMW	SERIE 3 BERLINA E90 (12→)	11,5	10,7
BMW	SERIE 3 COUPE' E90 (05→11)	10,0	10,9
BMW	SERIE 3 TOURING E90 No rails (05→11)	11,5	11,1
BMW	BMW SERIE 5 E39 (96→02)	10,3	8,8
BMW	SERIE 1 E87 (04→07)	10,2	8,5
BMW	SERIE 1 E81 (08→11)	10,2	8,5
BMW	SERIE 1 F20 (15→)	9,9	7,9
BMW	SERIE 1 F20 (11→)	9,1	7,0
CITROEN	C4 (04→09)	9,1	5,7
CITROEN	C4 PICASSO	5,4	2,4
CITROEN	NUOVA C5 (08→)	11,9	9,1
FIAT	IDEA No rails (05→)	11,6	7,6
FIAT	Panda (14→)	7,7	5,1
FIAT	STILO 3-5 P	13,8	10,1
FORD	FOCUS II 3-5P (05→10)	11,6	10,9
FORD	FOCUS II sw No rails (04→10)	11,6	9,6
FORD	FOCUS C-MAX (03→)	12,4	10,3
FORD	FOCUS S-MAX	10,2	8,5
LANCIA	LYBRA SW	5,7	5,6
LANCIA	MUSA (05→)	12,4	8,2
MAZDA	2 (DE) (07→14)	7,7	3,7
MERCEDES	CLASSE A W169 (04→07)	13,1	8,0
MERCEDES	CLASSE A W169 Restyling (08→)	12,4	7,6
MERCEDES	CLASSE B W245 (05→11)	12,1	6,7
MERCEDES	CLASSE E W 211 (02→09)	13,3	11,1
MITSUBISHI	ASX No rails	13,3	11,1
MITSUBISHI	LANCER (93→)	10,2	8,5
OPEL	ASTRA H (04→09)	7,9	6,6
OPEL	ASTRA H SW No rails (08→)	7,9	6,6
OPEL	ZAFIRA No rails (04→)	11,8	9,6
PEUGEOT	307 3-5 P (01→)	11,2	8,2
RENAULT	MEGANE II (02→08)	9,2	8,4
RENAULT	SCENIC II (03→08)	10,9	10,9
RENAULT	GRAND SCENIC II 7POSTI (04→08)	11,5	11,0
SAAB	9-3 4P (02→)	14,1	12,6
SAAB	9-3 5P SW (02→)	11,9	7,9





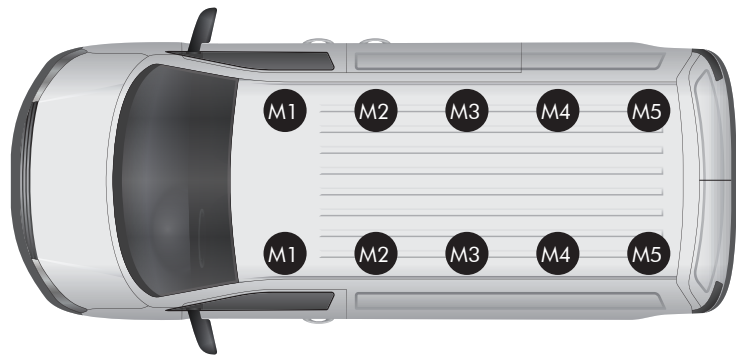

	X 4		X 8
	X 4		X 4
	X 4		X 4
	X 1		X 8
	X 1		

	X 1		X 4
	X 4		X 4
			X 2



	 	M1	M2	M3	M4	M5
CITROEN	JUMPY (→06)	3,0	2,7	2,7	2,7	2,2
CITROEN	NEMO no rail (08→)	9,9	7,2	5,1		
CITROEN	NEMO VAN (08→)	9,9	7,2	5,1		
FIAT	DOBLO' (00→10) CON GIRAFFONE	3,3	4,9			
FIAT	DOBLO' (00→10) SENZA GIRAFFONE	3,3	4,9	3,5		
FIAT	DOBLO' (09→)	6,7	5,3	3,5		
FIAT	DOBLO' (15→)	7,7	7,1	7,3		
FIAT	DOBLO' MAXI (10→)	7,3	6,5	6,5	3,3	
FIAT	DOBLO' MAXI (15→)	7,7	7,1	7,3		
FIAT	FIORINO(88→93)	3,2	2,8	1,8		
FIAT	FIORINO(94→08) CON GIRAFFONE	3,3	2,8			
FIAT	FIORINO(94→08) SENZA GIRAFFONE	3,3	2,8	1,8		
FIAT	FIORINO (08→)	9,9	7,2	5,1		
FIAT	QUBO no rail (08→)	9,9	7,2	5,1		
FIAT	SCUDO (→06)	3,0	2,7	2,7	2,7	2,2
FORD	CONNECT (02→)	1,5	1,5			
OPEL	COMBO TOUR (12→)	6,7	5,3	3,5		
OPEL	COMBO VAN (12→)	6,7	5,3	3,5		
OPEL	COMBO VAN PASSO LUNGO (12→)	7,3	6,5	6,5		3,3
PEUGEOT	BIPPER (08→)	9,9	7,2	5,1		
PEUGEOT	EXPERT (→06)	3,0	2,7	2,7	2,7	2,2
PEUGEOT	PARTNER TEPEE no rail (08→)	9,9	7,2	5,1		

1a

4 x

Clik!

K1 MEDIUM
 K1 PRO
 K1 PRO ALU

1b

4 x

K1
 K1 MEDIUM
 K1 PRO
 K1 PRO ALU

2

4 x

3

4 x

4

2 x M1

M1 M1b

→ M1

2 x M2

M2 M2b

← M2

