

TAB.1a



CASA AUTO	MODELLO	PORTE	ANNO
FIAT	Doblò Restyling		09→10
OPEL / VAUXHALL	Adam	3	13→
OPEL / VAUXHALL	Astra (J)	5	10→16
OPEL / VAUXHALL	Combo (C)		09→11
OPEL / VAUXHALL	Corsa (D)	3	06→10
OPEL / VAUXHALL	Corsa (D)	5	06→10
OPEL / VAUXHALL	Corsa (D)	3	11→14
OPEL / VAUXHALL	Corsa (D)	5	11→14
OPEL / VAUXHALL	Corsa (E)	3	15→
OPEL / VAUXHALL	Corsa / Corsavan (E)	5	15→
OPEL / VAUXHALL	Meriva (A)	5	03→09
OPEL / VAUXHALL	Meriva (B)	5	10→
OPEL / VAUXHALL	Zafira (C) Tourer	5	11→

M1	M2
6,1	6,1
8,4	3,3
7,5	4,6
6,1	6,1
9,7	4,5
9,7	5,1
9,7	4,5
9,7	5,1
9,7	4,5
9,7	5,1
8,7	6,5
10,2	7,4
10,8	9,1

G1	F1	G2	F2
24	mobile	24	mobile
24	mobile	24	mobile
24	mobile	24	mobile
24	mobile	24	mobile
24	mobile	24	mobile
24	mobile	24	mobile
24	mobile	24	mobile
24	mobile	24	mobile
24	mobile	24	mobile
24	mobile	24	mobile
24	mobile	24	mobile
24	mobile	24	mobile
24	mobile	24	mobile
24	mobile	24	mobile

T1	T2
X	X
X	X
X	X
X	X
X	X
X	X
X	X
X	X
X	X
X	X
X	X
X	X
X	X

X = predisposizione originale



TAB.1b



CASA AUTO	MODELLO	PORTE	ANNO
VOLKSWAGEN	Polo III (6N)	3-5	95→99
VOLKSWAGEN	Polo III (6N2)	3-5	99→03

M1	M2
2,8	1,3
2,8	1,3

G1	F1	G2	F2
32	mobile	32	mobile
32	mobile	32	mobile

T1	T2
X	X
X	X

1a

4 x

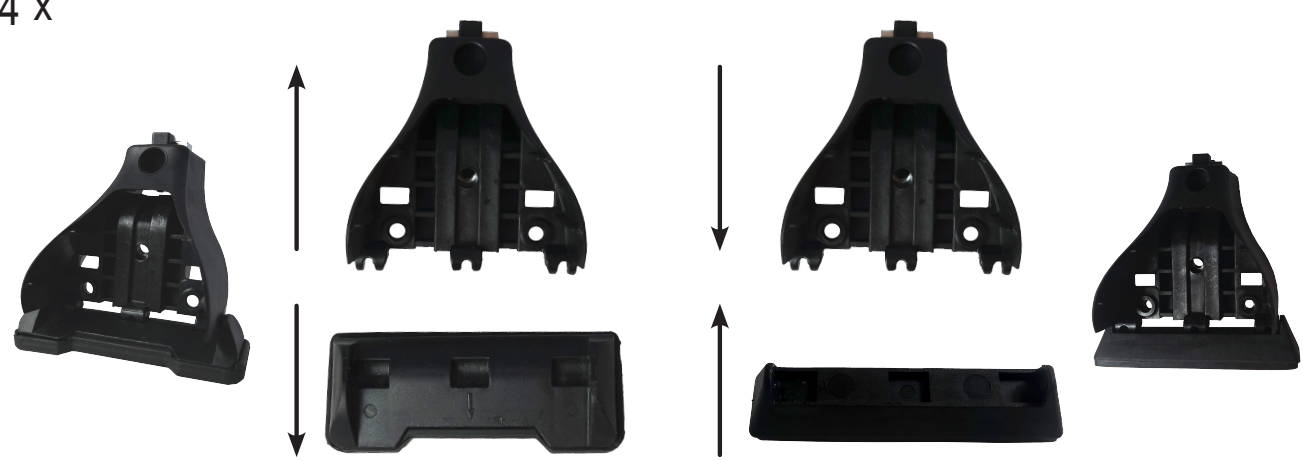

1

 Tab. 1:
M1
M2

4 x

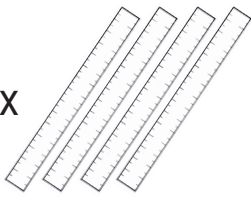

2 x M1

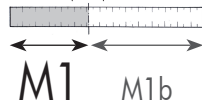

2 x M2

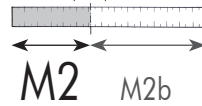

Tagliare i 4 metri in dotazione alla misura M1 ed M2 riportate in tabella

2

2 x



M1 - M2

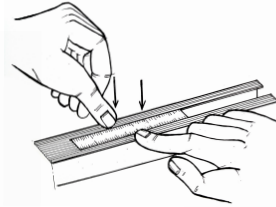
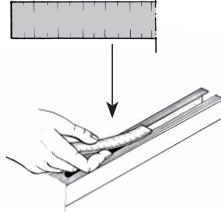

Inserire il metro tagliato in misura M1 nelle 2 cave della barra anteriore, portandolo fine a fine corsa.
Ripetere l'operazione per la barra posteriore con i metri tagliati in misura M2.

3

4 x

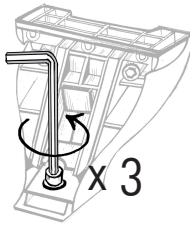
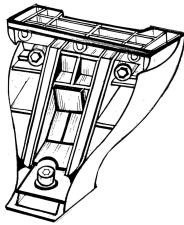

Prendere i 4 piedi dalla scatola, allentare la vite affinché i piedi possano entrare nella cava.
Prendere il primo piede ed inserirlo in cava facendo **ATTENZIONE** a non sormontare il metro precedentemente inserito, stringere con forza la vite del piede.
Ripetere l'operazione per tutti i 4 piedi ciascuno in una cava.

5 Nm

K1

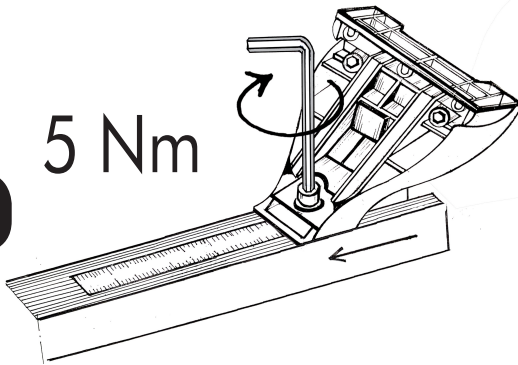

5 Nm

K1pro

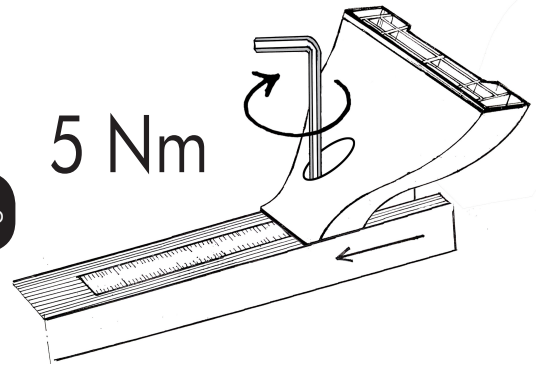

4

M1b - M2b



Inserire l'avanzo del metro tagliato (M1b per la barra anteriore ed M2b per la barra posteriore) per coprire la cava scoperta.

Ripetere l'operazione per tutte e 2 le barre.
Inserire, infine, i 4 tappi come indicato in figura.

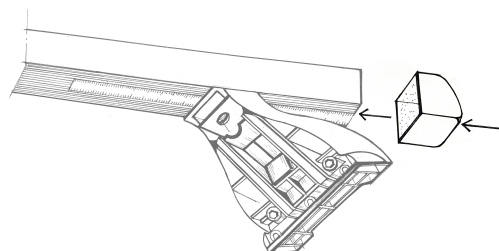
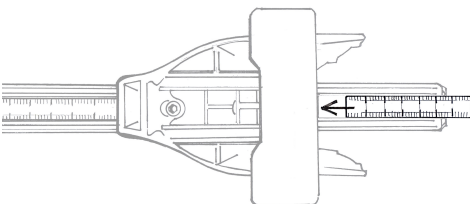

5



Tab. 1:
G1-F1
G2-F2

4 x 32 4 x 24



8x16

Assemblare le 4 GANASCINE come mostrato in figura, facendo ATTENZIONE a rispettare le misure riportate in tabella.
Lasciare la parte inferiore della ganascina lasca.

6

8x50

4 x

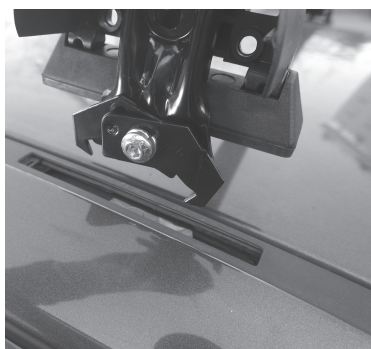

Posizionare la barra anteriore e la barra posteriore sul tetto dell'autovettura. Fissare le ganascine ai 4 piedi facendo ATTENZIONE a non stringere completamente la vite.



Stringere con forza la vite superiore facendo ATTENZIONE a non spostare la centratura delle barre. Per ottenere il risultato corretto stringere le viti alternando il lato destro al lato sinistro in maniera uniforme.

7a



K1

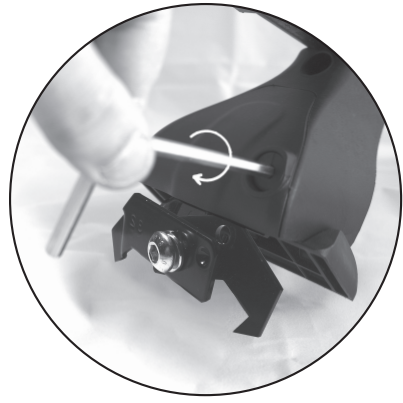

7b



K1pro

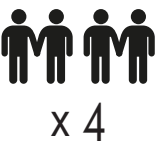
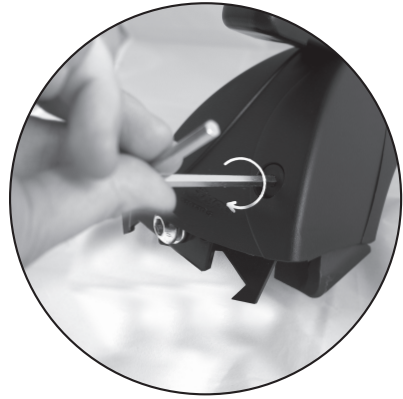

MAX
55 kg



NO

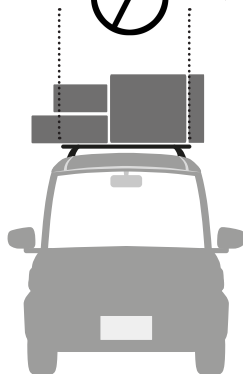

OK

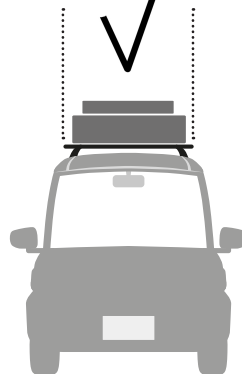

NO

