

3

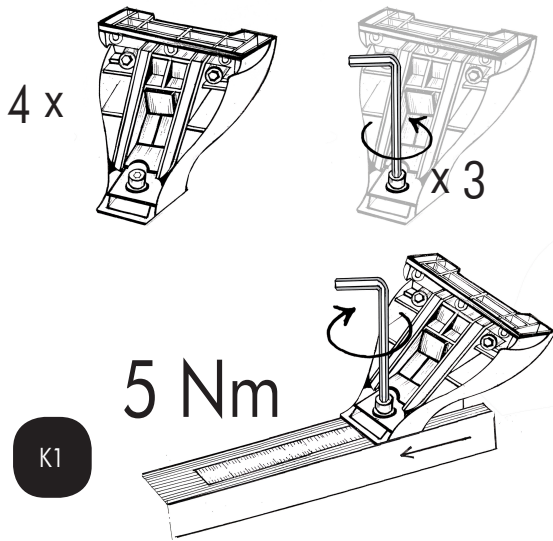

Prendere i 4 piedi dalla scatola, allentare la vite affinché i piedi possano entrare nella cava.
Prendere il primo piede ed inserirlo in cava facendo **ATTENZIONE** a non sormontare il metro precedentemente inserito, stringere con forza la vite del piede.
Ripetere l'operazione per tutti i 4 piedi ciascuno in una cava.

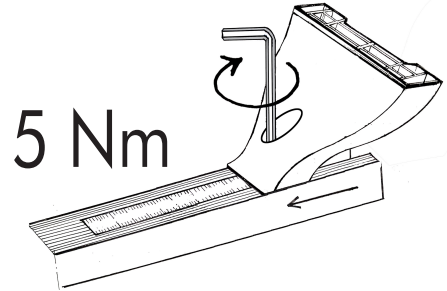

4

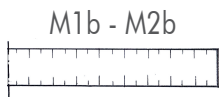

Inserire l'avanzo del metro tagliato (M1b per la barra anteriore ed M2b per la barra posteriore) per coprire la cava scoperta.
Ripetere l'operazione per tutte e 2 le barre.
Inserire, infine, i 4 tappi come indicato in figura.

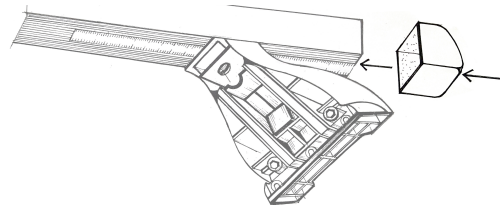
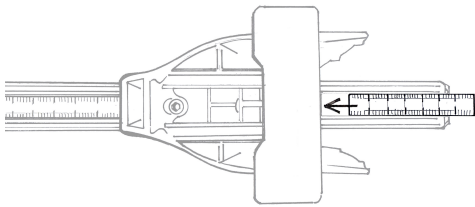

5



Tab. 1:
G1-F1
G2-F2

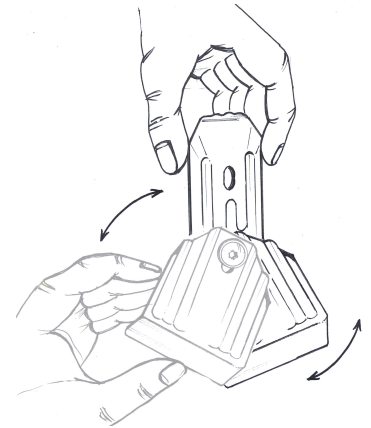
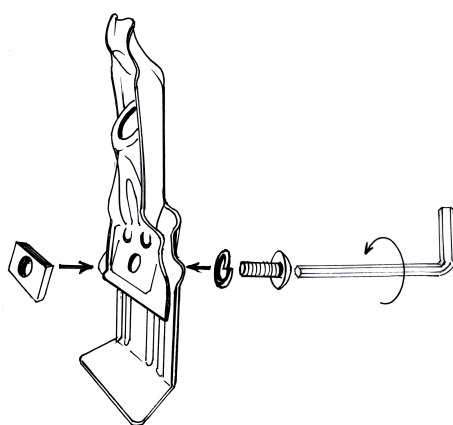
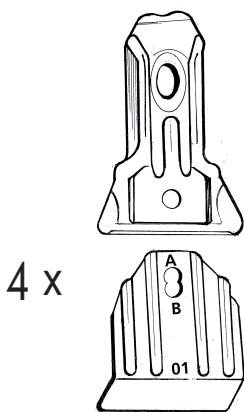

Assemblare le 4 GANASCINE come mostrato in figura, facendo **ATTENZIONE** a rispettare le misure riportate in tabella.
Lasciare la parte inferiore della ganascina lasca.

6

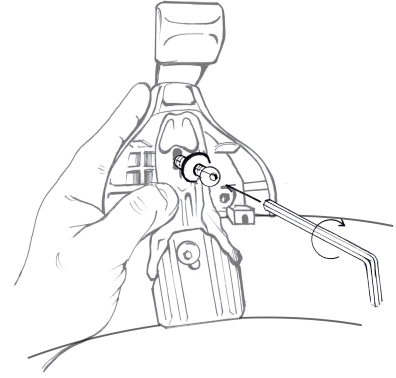
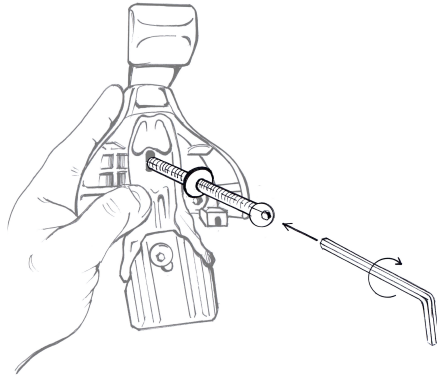
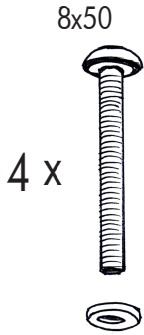

Posizionare la barra anteriore e la barra posteriore sul tetto dell'autovettura. Fissare le ganascine ai 4 piedi facendo **ATTENZIONE** a non stringere completamente la vite.

7

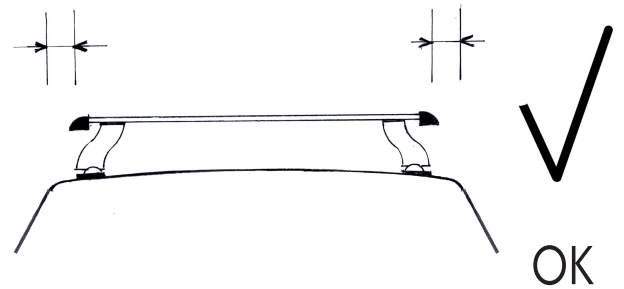
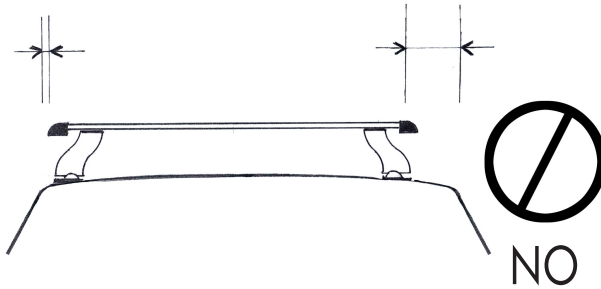

8

4 x
5x16

CASA AUTO	MODELLO	PORTE	ANNO
RENAULT	Kadjar	5	15→

4 x
6x12

CASA AUTO	MODELLO	PORTE	ANNO
RENAULT	Talisman	4	15→
TOYOTA	Prius IV (XW50)	5	15→

4 x
6x16

CASA AUTO	MODELLO	PORTE	ANNO
ALFA ROMEO	Giulia	4	16→
ALFA ROMEO	Giulietta	5	10→
AUDI	A3 (8V) Sedan	4	13→
AUDI	S3 (8VS) Sedan	4	13→
FORD	Mondeo III	5	07→14
FORD	Mondeo III Station Wagon	5	07→10
FORD	Mondeo III Station Wagon	5	10→14
PEUGEOT	208	5	15→
SEAT	Ibiza V	5	17→
SKODA	Fabia III (NJ)	5	15→
SKODA	Octavia III (5E)	4	13→
SKODA	Rapid (NH1) Spaceback	5	13→
SKODA	Superb (3V)	4	15→

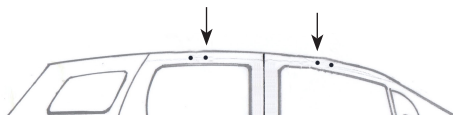

ATTENZIONE: per il modello SKODA Superb (3V) utilizzare i fori interni della predisposizione originale.

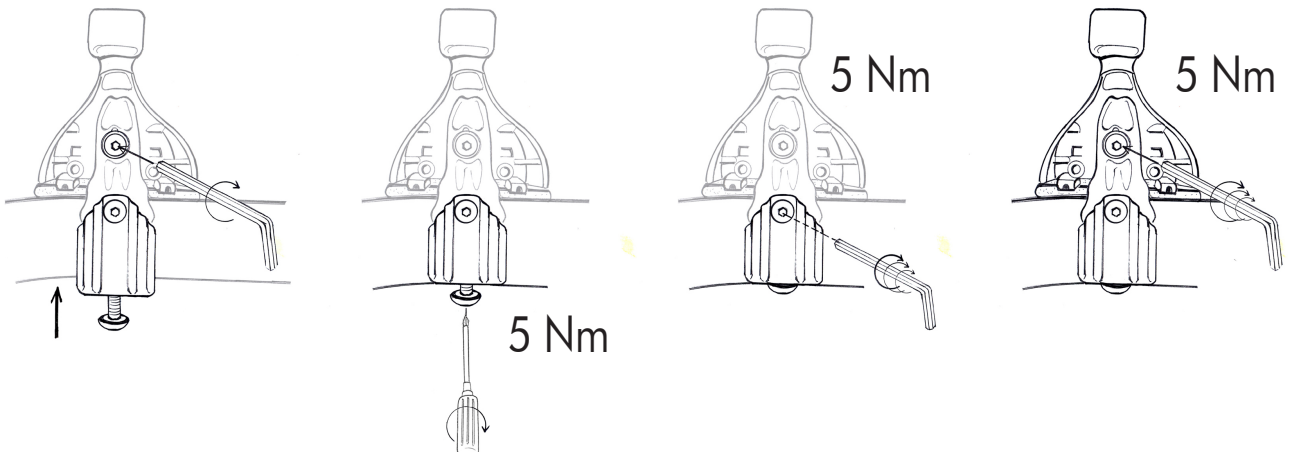

Stringere la vite superiore fino ad accompagnare la parte inferiore della ganascina al tetto. Stringere la vite inferiore arrivando a fine corsa. Stringere con forza la vite di congiunzione della ganascina. Stringere con forza la vite superiore facendo **ATTENZIONE** a non spostare la centratura delle barre. Per ottenere il risultato corretto stringere le viti alternando il lato destro al lato sinistro in maniera uniforme.

9a



K1



x 4

9b



K1pro



x 4

MAX
55 kg



NO

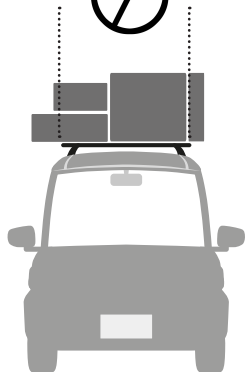

OK

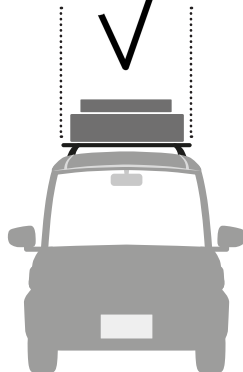

NO

