

CASA AUTO	MODELLO	PORTE	ANNO
HYUNDAI	Atos	5	97→08
HYUNDAI	Atos Prime	5	99→08
HYUNDAI	ix20	5	10→
KIA	Picanto (SA)	5	04→10
KIA	Rio (UB)	4	11→16
KIA	Rio (UB) Hatchback	5	11→15
KIA	Venga (No per tetto vetro-Not for glass roof)	5	10→14
LEXUS	IS (XE10)	4	98→05
MERCEDES	190 (W201)	4	83→93
MERCEDES	200 / 300 Station Wagon (W124)	5	85→94
MERCEDES	C (W202)	4	93→00
MERCEDES	E (W210)	4	95→02
NISSAN	Cube	5	08→13
SKODA	Fabia II (5J)	5	07→14
SKODA	Superb (3U)	4	01→08
SSANGYONG	Tivoli	5	15→
TOYOTA	Carina	4	92→97
TOYOTA	Corolla Verso	5	00→04
TOYOTA	Corolla Verso	5	04→07
TOYOTA	Rav 4 (XA30)	5	05→12

M1	M2
10,6	9,8
10,8	11,1
7,7	6,0
2,6	3,8
4,9	4,9
4,9	4,9
7,0	5,6
3,8	3,8
3,8	2,8
6,0	6,0
6,0	6,3
7,5	7,5
9,6	9,7
12,9	12,9
11,4	11,4
14,5	13,4
2,3	0,7
5,9	5,9
10,5	10,5
7,6	6,3

G1	F1	G2	F2
03	A	03	B
03	B	03	B
03	A	03	B
03	B	03	B
03	A	03	B
03	A	03	B
03	A	03	B
03	B	03	B
03	B	03	B
03	B	03	B
03	A	03	B
03	A	03	B
03	B	03	B
03	B	03	B
03	A	03	B
03	A	03	B
03	B	03	B
03	B	03	B
03	A	03	B
03	A	03	B

T1	T2
20	50
25	40
30	27
25	50
28	32
28	32
27	40
X	X
X	X
X	X
20	31
22	33
33	35
21	55
24	46
24	45
X	X
22	52
25	42
30	40

X = predisposizione originale



X =

1

 Tab. 1:
M1
M2

4 x

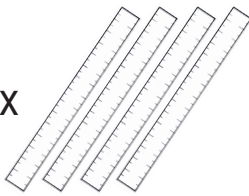

2 x M1

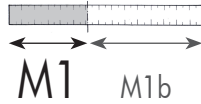

2 x M2

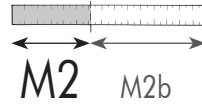

Tagliare i 4 metri in dotazione alla misura M1 ed M2 riportate in tabella

2

2 x



M1 - M2

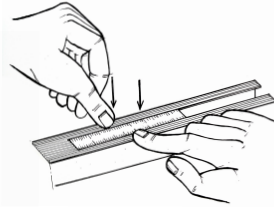
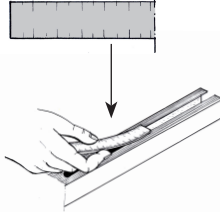

Inserire il metro tagliato in misura M1 nelle 2 cave della barra anteriore, portandolo fine a fine corsa.
Ripetere l'operazione per la barra posteriore con i metri tagliati in misura M2.

3

4 x

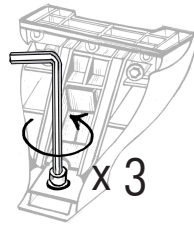
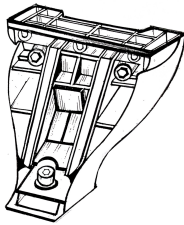

Prendere i 4 piedi dalla scatola, allentare la vite affinché i piedi possano entrare nella cava.
Prendere il primo piede ed inserirlo in cava facendo **ATTENZIONE** a non sormontare il metro precedentemente inserito, stringere con forza la vite del piede.
Ripetere l'operazione per tutti i 4 piedi ciascuno in una cava.

5 Nm

K1

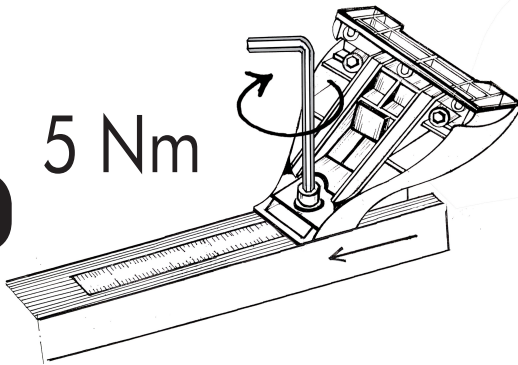

5 Nm

K1pro

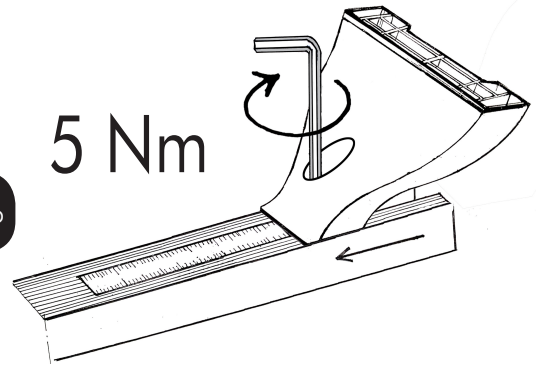

4

M1b - M2b



Inserire l'avanzo del metro tagliato (M1b per la barra anteriore ed M2b per la barra posteriore) per coprire la cava scoperta.

Ripetere l'operazione per tutte e 2 le barre.
Inserire, infine, i 4 tappi come indicato in figura.

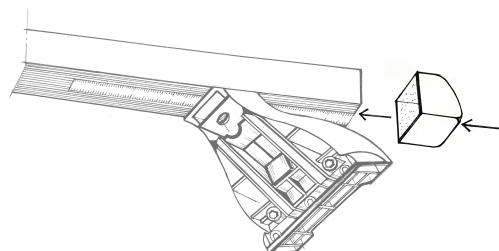
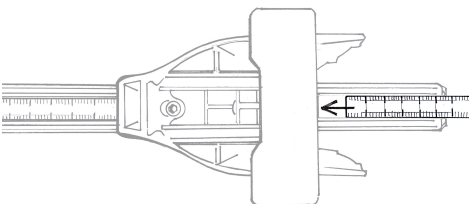

5

 Tab. 1:
G1-F1
G2-F2

4 x

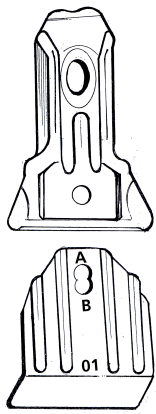

8x14

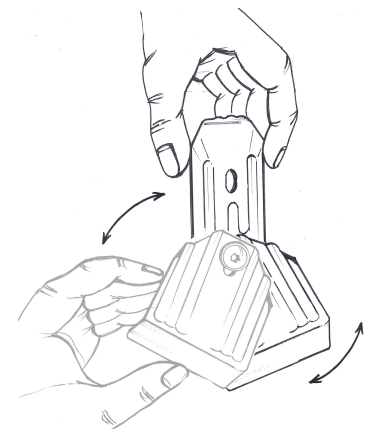
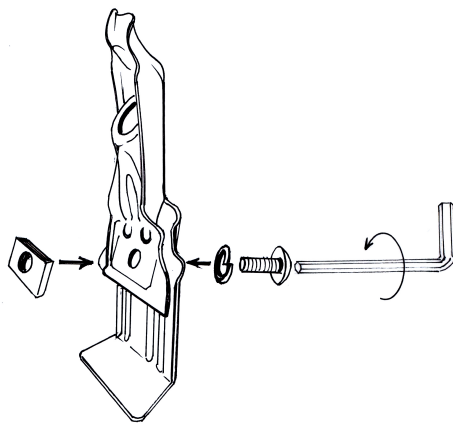

Assemblare le 4 GANASCINE come mostrato in figura, facendo **ATTENZIONE** a rispettare le misure riportate in tabella. Lasciare la parte inferiore della ganascina lasca.

6

8x50

4 x

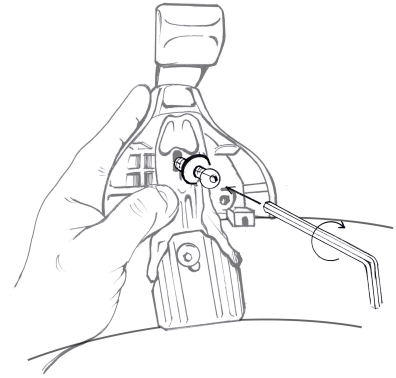
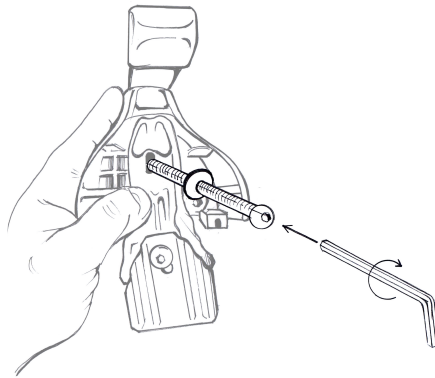

Posizionare la barra anteriore e la barra posteriore sul tetto dell'autovettura. Fissare le ganascine ai 4 piedi facendo **ATTENZIONE** a non stringere completamente la vite.

7

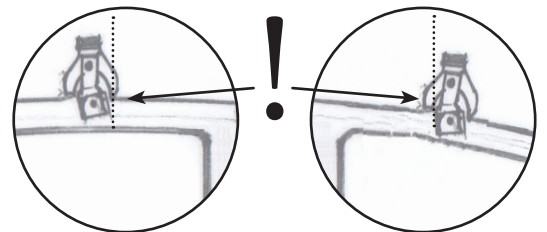
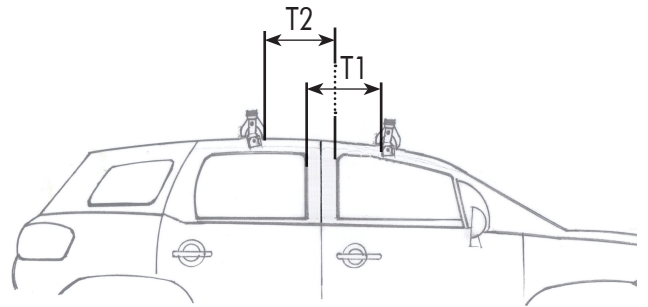
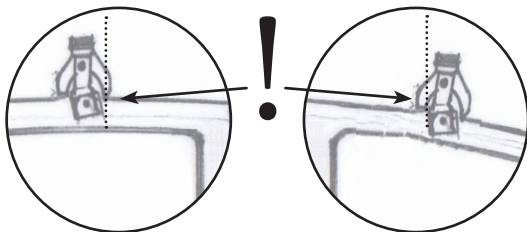
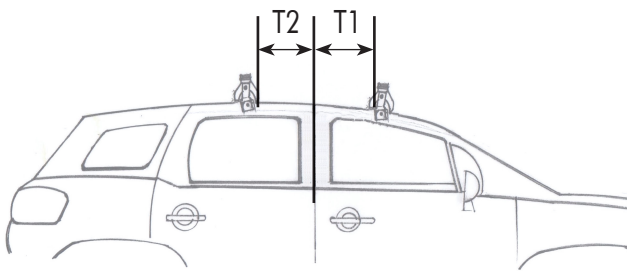
 Tab. 1:
T1
T2

8

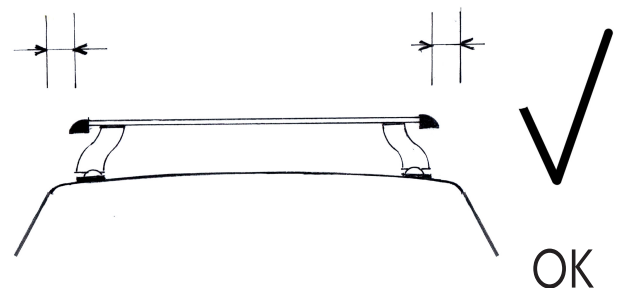
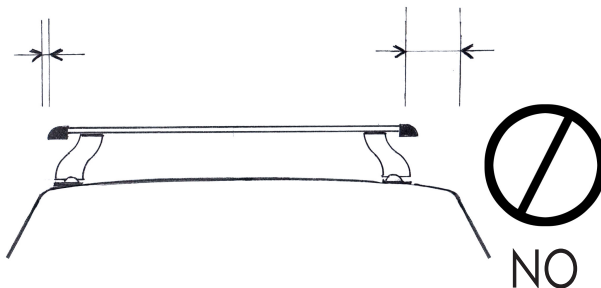

9

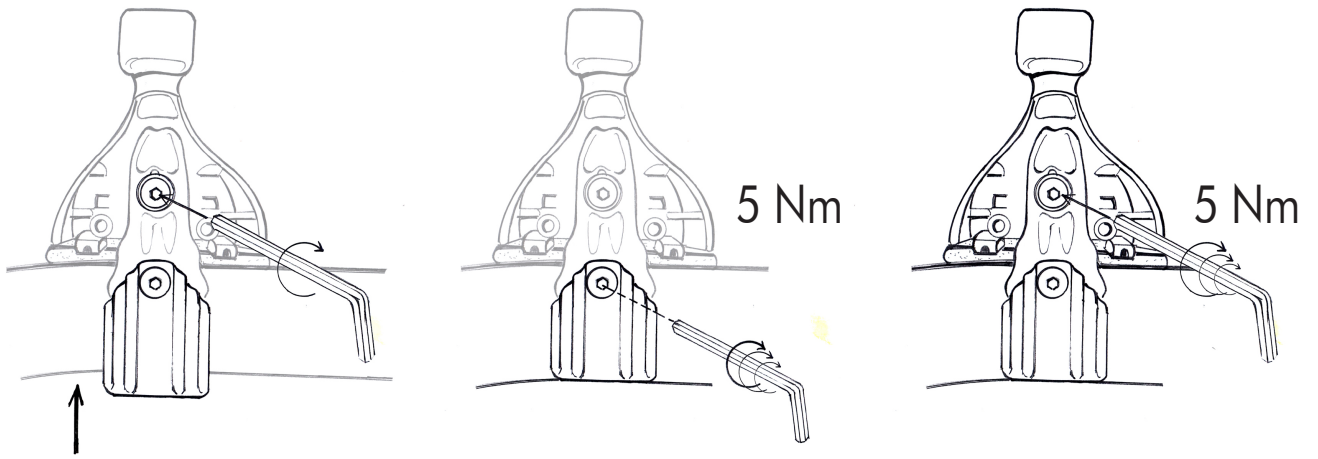

Stringere la vite superiore fino ad accompagnare la parte inferiore della ganascina al tetto. Stringere con forza la vite inferiore. Stringere con forza la vite superiore facendo **ATTENZIONE** a non spostare la centratura delle barre. Per ottenere il risultato corretto stringere le viti alternando il lato destro al lato sinistro in maniera uniforme.

10a



K1



x 4

10b



K1pro



x 4

MAX
55 kg



NO

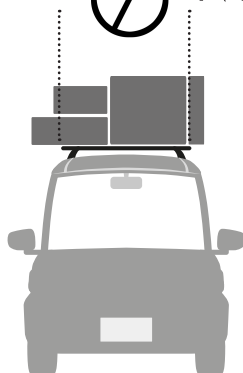

OK

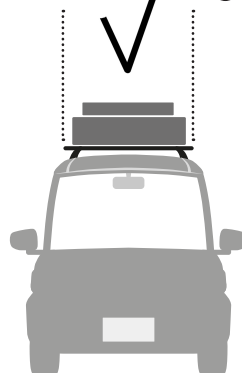

NO

