

CASA AUTO	MODELLO	PORTE	ANNO
BMW	Serie 2 (F46) Gran Tourer	5	15→
HYUNDAI	Genesis	4	15→
HYUNDAI	Tucson (TL)	5	15→
MAZDA	3 (BM)	5	14→
MAZDA	6 (GJ)	4	16→
TOYOTA	C-HR	5	16→

M1	M2
7,5	7,2
7,6	6,6
10,1	8,9
11,2	9,8
10,7	9,2
5,9	7,4

G1	F1	G2	F2
01	A	21	1 foro A
01	A	21	1 foro A
01	A	21	1 foro A
01	A	21	1 foro A
01	A	21	1 foro A
01	A	21	1 foro A

T1	T2
17	51
20	40
24	40
25	35
25	45
33	36



1

 Tab. 1:  
M1  
M2

4 x

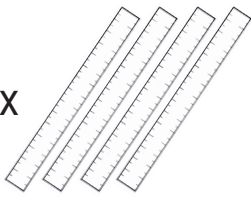

2 x M1

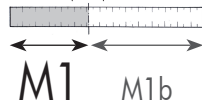

2 x M2

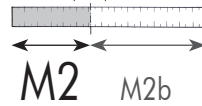

Tagliare i 4 metri in dotazione alla misura M1 ed M2 riportate in tabella

2

2 x



M1 - M2

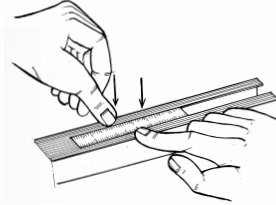
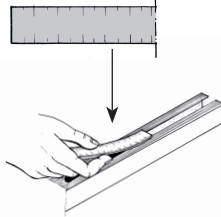

Inserire il metro tagliato in misura M1 nelle 2 cave della barra anteriore, portandolo fine a fine corsa.  
Ripetere l'operazione per la barra posteriore con i metri tagliati in misura M2.

3

4 x

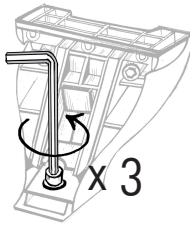
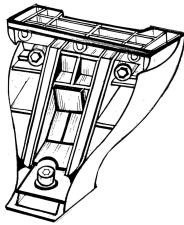

Prendere i 4 piedi dalla scatola, allentare la vite affinché i piedi possano entrare nella cava.  
Prendere il primo piede ed inserirlo in cava facendo **ATTENZIONE** a non sormontare il metro precedentemente inserito, stringere con forza la vite del piede.  
Ripetere l'operazione per tutti i 4 piedi ciascuno in una cava.

5 Nm

K1

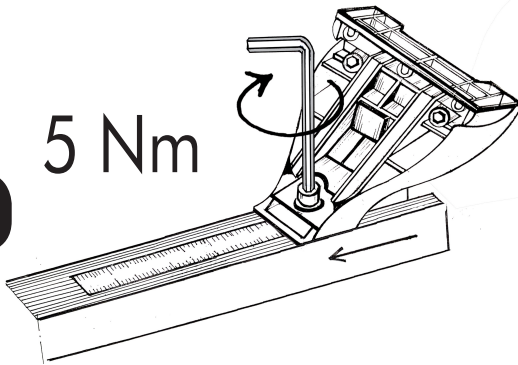

5 Nm

K1pro

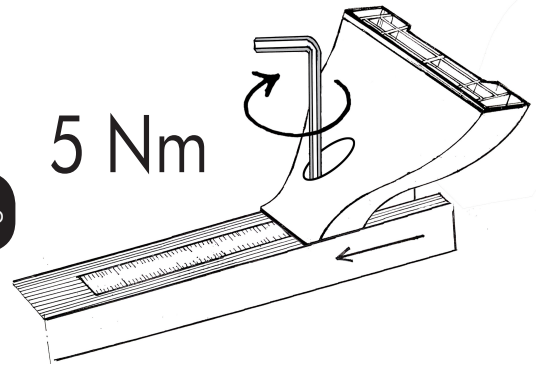

4

M1b - M2b



Inserire l'avanzo del metro tagliato (M1b per la barra anteriore ed M2b per la barra posteriore) per coprire la cava scoperta.

Ripetere l'operazione per tutte e 2 le barre.  
Inserire, infine, i 4 tappi come indicato in figura.

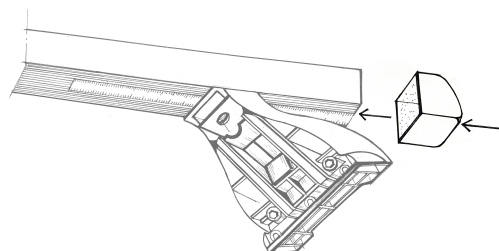
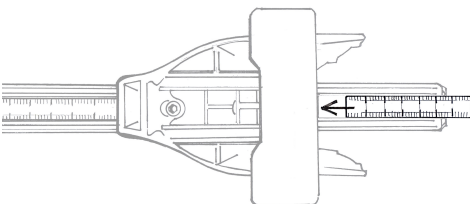

5

 Tab. 1:  
G1-F1  
G2-F2

4 x

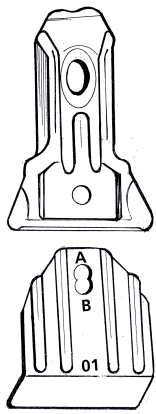

8x14

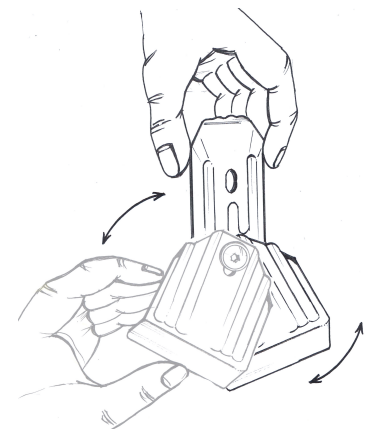
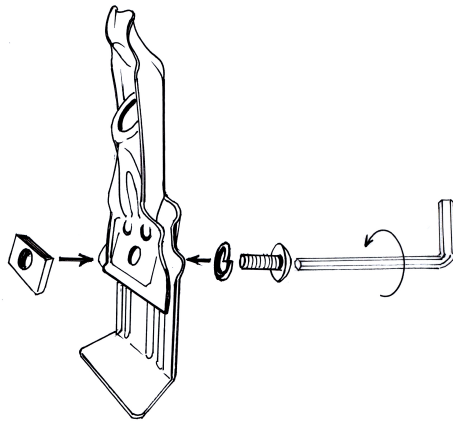

Assemblare le 4 GANASCINE come mostrato in figura, facendo **ATTENZIONE** a rispettare le misure riportate in tabella. Lasciare la parte inferiore della ganascina lasca.

6

8x50

4 x

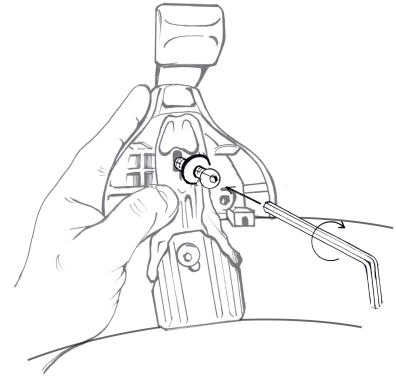
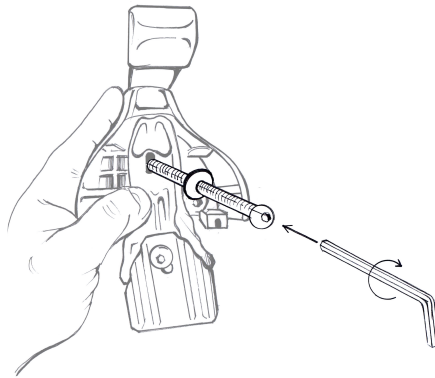

Posizionare la barra anteriore e la barra posteriore sul tetto dell'autovettura. Fissare le ganascine ai 4 piedi facendo **ATTENZIONE** a non stringere completamente la vite.

7

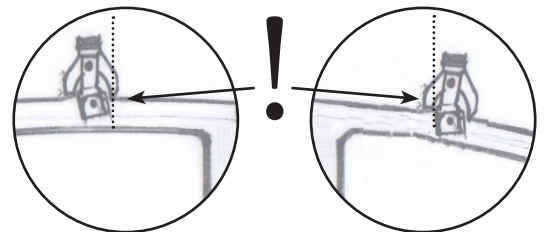
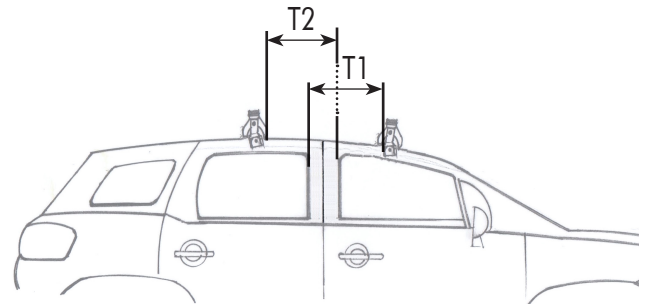
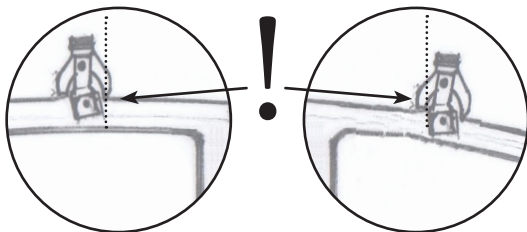
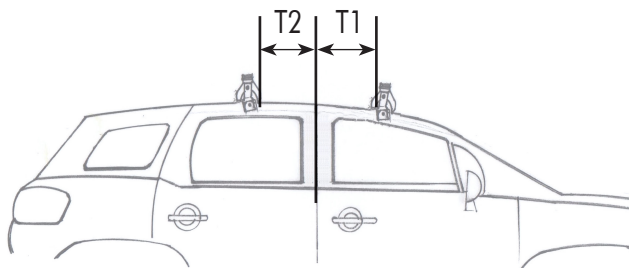
 Tab. 1:  
T1  
T2

8

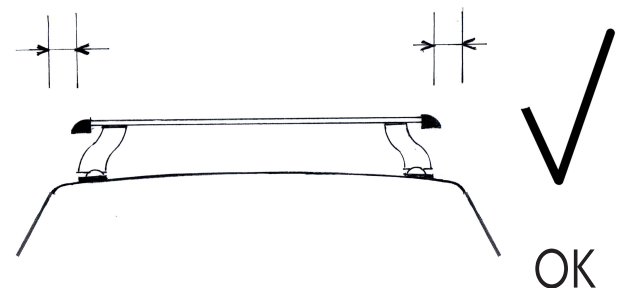
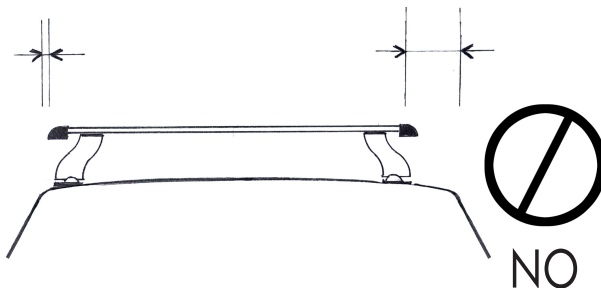

9

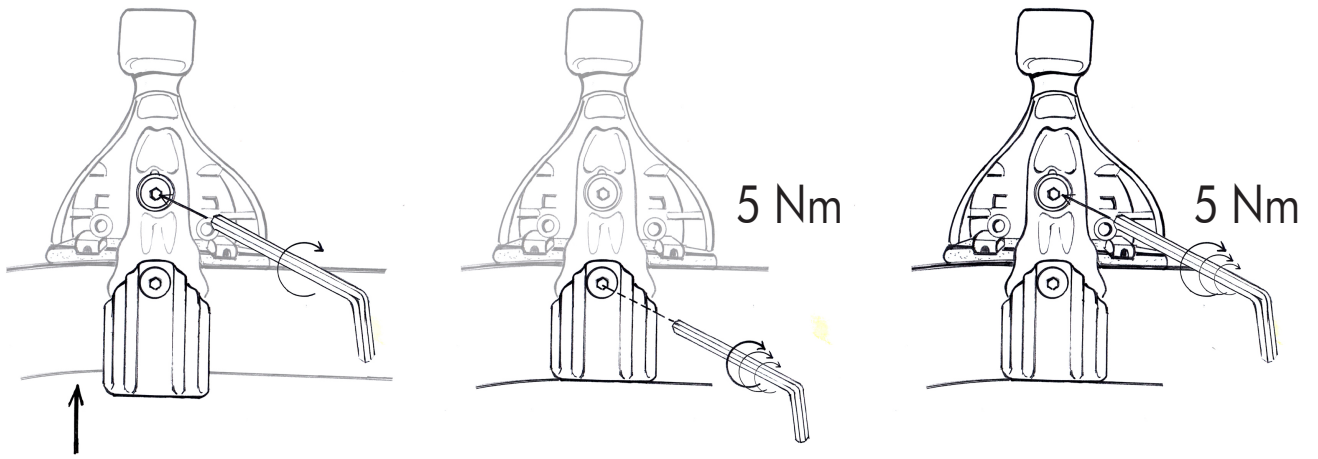

Stringere la vite superiore fino ad accompagnare la parte inferiore della ganascina al tetto. Stringere con forza la vite inferiore. Stringere con forza la vite superiore facendo **ATTENZIONE** a non spostare la centratura delle barre. Per ottenere il risultato corretto stringere le viti alternando il lato destro al lato sinistro in maniera uniforme.

10a



K1



x 4

10b



K1pro



x 4

MAX  
55 kg



NO

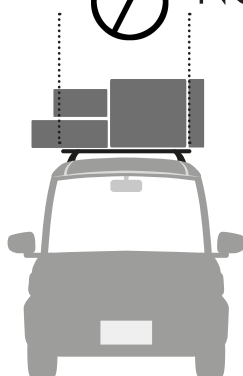

OK

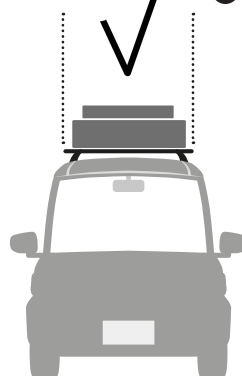

NO

